

KEY FEATURES

- Wide range of models, from production baking to rethermalisation.
- Fan forced for high production capacity.
- Stainless steel or vitreous enamel construction for durability and ease of cleaning.
- Gastronorm and baking sheet compatibility.
- Cook and hold facility.
- 12 months parts & labour warranty.
- 10 year parts availability guarantee.
- Australian born & bred.



X700



RTC-10

MODELS

X700A, X702A

RTC-10

EZ26 (EZYBAKE)



EZ26

X700

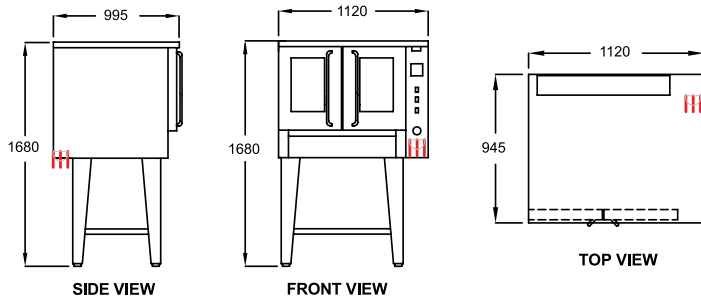

MODEL: X700 Specifications:

Dimensions (WxDxH):	1120 x 995 x 1680 mm
Holding Capacity:	20 1/1 trays
Shelves:	5
Slides:	10
Electric Connection:	3 phase, 415V + N + E
Rating:	13 kW
Weight:	250 kg
Packed:	1.8 m ³

X702

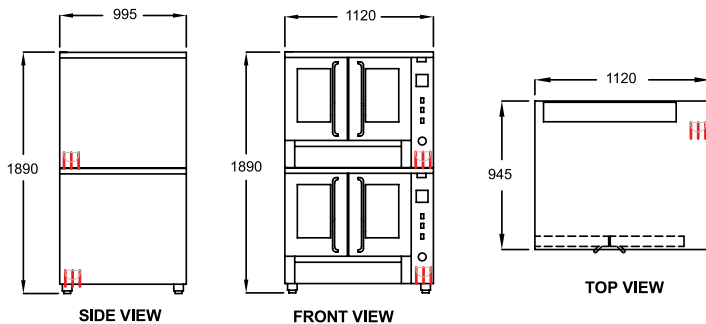

MODEL: X702 Specifications:

Dimensions (WxDxH):	1120 x 995 x 1890 mm
Holding Capacity:	40 1/1 trays
Shelves:	10
Slides:	20
Electric Connection:	3 phase, 415V + N + E
Rating:	26 kW
Weight:	500 kg
Packed:	2.0 m ³

RTC

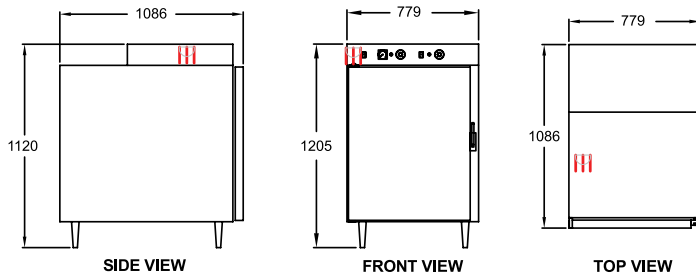

MODEL: RTC Specifications:

Dimensions (WxDxH):	779 x 1086 x 1120 mm
Holding Capacity:	20 1/1 trays or 10 bakers trays
Shelves:	5
Slides:	10
Electric Connection:	3 phase, 415V + N + E
Rating:	13 kW
Weight:	190 kg
Packed:	1.0 m ³

EZYBAKE

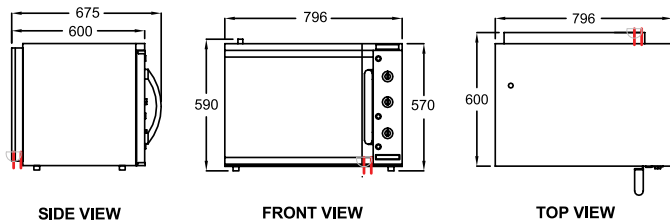

MODEL: EZYBAKE Specifications:

Dimensions (WxDxH):	1120 x 995 x 1680 mm
Oven Size (WxDxH):	1120 x 995 x 1680 mm
Functions:	Bake, Grill, Cook & Hold
Electric Connection:	240V, 15 amp
Rating:	3.2 kW
Weight:	65 kg
Packed:	0.3 m ³

||| 415V, 3 PHASE POWER || 240V, 1 PHASE POWER

Goldstein Eswood continually works on improving our products, so dimensions may change without notice. For any construction critical dimensions please check with us.

GOLDSTEIN ESWOOD
211 - 217 Woodpark Rd SMITHFIELD NSW 2164
T: 1800 013 123 F: 02 96045420
E: sales@goldsteineswood.com.au

